

Hygro-Thermo-Baro Transmitter Compact

Instruction for Use

1.1006.54.xxx

At start of software version V3.09



Cable version



Plug version

Dok. No. 021883/01/23

THE WORLD OF WEATHER DATA

Safety Instructions

- Before operating with or at the device/product, read through the operating instructions. This manual contains instructions which should be followed on mounting, start-up, and operation. A non-observance might cause:
 - failure of important functions
 - endangerment of persons by electrical or mechanical effect
 - damage to objects
- Mounting, electrical connection and wiring of the device/product must be carried out only by a qualified technician who is familiar with and observes the engineering regulations, provisions and standards applicable in each case.
- Repairs and maintenance may only be carried out by trained staff or **Adolf Thies GmbH & Co. KG**. Only components and spare parts supplied and/or recommended by **Adolf Thies GmbH & Co. KG** should be used for repairs.
- Electrical devices/products must be mounted and wired only in a voltage-free state.
- **Adolf Thies GmbH & Co. KG** guarantees proper functioning of the device/products provided that no modifications have been made to the mechanics, electronics or software, and that the following points are observed:
- All information, warnings and instructions for use included in these operating instructions must be taken into account and observed as this is essential to ensure trouble-free operation and a safe condition of the measuring system / device / product.
- The device / product is designed for a specific application as described in these operating instructions.
- The device / product should be operated with the accessories and consumables supplied and/or recommended by **Adolf Thies GmbH & Co. KG** .
- Recommendation: As it is possible that each measuring system / device / product may, under certain conditions, and in rare cases, may also output erroneous measuring values, it is recommended using redundant systems with plausibility checks for **security-relevant applications**.

Environment

- As a longstanding manufacturer of sensors Adolf Thies GmbH & Co KG is committed to the objectives of environmental protection and is therefore willing to take back all supplied products governed by the provisions of "ElektroG" (German Electrical and Electronic Equipment Act) and to perform environmentally compatible disposal and recycling. We are prepared to take back all Thies products concerned free of charge if returned to Thies by our customers carriage-paid.
- Make sure you retain packaging for storage or transport of products. Should packaging however no longer be required, please arrange for recycling as the packaging materials are designed to be recycled.



Documentation

- © Copyright **Adolf Thies GmbH & Co KG**, Göttingen / Germany
- Although these operating instructions have been drawn up with due care, **Adolf Thies GmbH & Co KG** can accept no liability whatsoever for any technical and Typeographical errors or omissions in this document that might remain.
- We can accept no liability whatsoever for any losses arising from the information contained in this document.
- Subject to modification in terms of content.
- The device / product should not be passed on without the/these operating instructions.

Table of contents

1	Models	5
1.1	Scaling for sensors with analog output	5
2	Application	6
3	Setup and Mode of Operation	7
4	Recommendation Side Selection / Standard Installation	8
5	Installation.....	8
5.1	Electrical Mounting	9
5.2	Connection Diagram.....	9
5.3	Cable Assignment	10
5.4	Plug Assignment.....	10
5.4.1	Cable	11
5.4.2	Cable Shield.....	11
5.4.3	Plug and Cable Mounting	12
6	Maintenance	13
7	Firmware Update	13
8	Bootloader	13
9	Analog Output.....	14
10	Interface.....	16
10.1	Command Interpreter THIES	16
10.1.1	Telegram Formats.....	18
10.1.2	Generation Check Sum:.....	19
10.1.3	Status Information:.....	19
10.2	Commands and Description	20
10.2.1	Command BR	21
10.2.2	Command CF	21
10.2.3	Command CI.....	22
10.2.4	Command FB.....	22
10.2.5	Command HW	23
10.2.6	Command ID.....	23
10.2.7	Command KY	24
10.2.8	Command LL	24
10.2.9	Command OL	25
10.2.10	Command OR.....	26
10.2.11	Command PO	26
10.2.12	Command RD	27
10.2.13	Command RS	27
10.2.14	Command SF.....	28
10.2.15	Command SH	28
10.2.16	Command SN	29
10.2.17	Command TA.....	29
10.2.18	Command TR	30
10.2.19	Command TT.....	30
10.2.20	Command EFS	31
10.2.21	Command AVN	34
10.2.22	Command AVX	34
10.2.23	Command BVN	35
10.2.24	Command BVX	35
10.2.25	Command CVN.....	36
10.2.26	Command CVX.....	36
10.2.27	Command OSN	37
10.2.28	Command OSX.....	37
10.3	Command Interpreter MODBUS RTU.....	38
10.3.1	Measured Values (Input Register).....	39

10.3.2	Commands (Holding Register)	40
10.3.3	Device detection (Read Device Identification)	41
11	Data Telegrams	41
11.1	Telegram 1	41
11.2	Telegram 2	42
11.3	Telegram 3	43
11.4	Telegram 4	44
11.5	Telegram 5	45
11.1	Telegram 6	45
11.2	Telegram 7	46
12	Technical Data	47
12.1	Power consumption	48
13	Dimensional Drawing Cable Version	49
14	Dimensional Drawing Plug Version	50
15	Accessories (optional).....	51
16	Appendix.....	52
16.1	Calibration of the Sensor	52
16.2	Calibration of Temperature / Humidity	52
16.3	Calibration of Air Pressure	52
16.3.1	Calibration of the air pressure in the pressure chamber	53
16.3.2	Calibration of the air pressure via hose connections	54
16.4	Calculation of Air Pressure	55
16.5	Exchange of Hygro-Thermo Sensor Element.....	56
16.6	Table and Figures Overview	58
17	EC-Declaration of Conformity	59
18	UK-CA-Declaration of Conformity	60
19	More Information / Documents as download	61

[The list of tables and figures can be found in the appendix.](#)

1 Models

Order no.	Serial interface / Data format / Analogue Output	Supply	Model with
1.1006.54.080	RS 485 HD / THIES ASCII / -	6 ... 30V DC	5m cable
1.1006.54.081	RS 485 HD / MODBUS RTU / -	6 ... 30V DC	5m cable
1.1006.54.087	RS 485 HD / THIES ASCII / -	6 ... 30V DC	0.3m cable with plug
1.1006.54.141	RS 485 HD / THIES ASCII / 4 ... 20 mA	15 ... 30V DC	5m cable
1.1006.54.160	RS 485 HD / THIES ASCII / 0 ... 1 V	6 ... 30V DC	5m cable
1.1006.54.161	RS 485 HD / THIES ASCII / 0 ... 10 V	15 ... 30V DC	5m cable
1.1006.54.741	RS 485 HD / THIES ASCII / 4 ... 20 mA	15 ... 30V DC	Plug*
1.1006.54.760	RS 485 HD / THIES ASCII / 0 ... 1 V	6 ... 30V DC	Plug*
1.1006.54.761	RS 485 HD / THIES ASCII / 0 ... 10 V	15 ... 30V DC	Plug*
1.1006.54.780	RS 485 HD / THIES ASCII / -	6 ... 30V DC	Plug*
1.1006.54.781	RS 485 HD / MODBUS RTU / -	6 ... 30V DC	Plug*

*Incl. Mating connector

1.1 Scaling for sensors with analog output

Order no.	Analogue output	Rel. humidity scaling	Air temperature scaling	Air pressure scaling
1.1006.54.141	4 ... 20 mA	0 ... 100%	-30 ... 70°C	800 ... 1100hPa
1.1006.54.160	0 ... 1 V	0 ... 100%	-30 ... 70°C	800 ... 1100hPa
1.1006.54.161	0 ... 10 V	0 ... 100%	-30 ... 70°C	800 ... 1100hPa
1.1006.54.741	4 ... 20 mA	0 ... 100%	-30 ... 70°C	800 ... 1100hPa
1.1006.54.760	0 ... 1 V	0 ... 100%	-30 ... 70°C	800 ... 1100hPa
1.1006.54.761	0 ... 10 V	0 ... 100%	-30 ... 70°C	800 ... 1100hPa

[See 14. Accessories \(optional\)](#)

The following parts are included in the scope of delivery:

- 1 x Hygro-Thermo-Baro transmitter Compact.
- 1 x Instructions for use short version (included in the package).
- 1 x Factory setting (included in the package).

The inductions for use for the Hygro-Thermo-Baro Transmitter Compact are available for download under the following link:

https://www.thiesclima.com/db/dnl/1.1006.54.xxx_Hygro_Thermo_Barо_Compact_eng.pdf

2 Application

Hygro-Thermo-Baro transmitters from our *COMPACT* series are designed to measure relative humidity, air temperature and barometric air pressure.

This sensor is above all intended for use at meteorological measuring stations for connection to data logger systems. Thanks to its universal interface the sensor can also be used as a single solution in every application suitable for the purpose.

The use of high-quality sensors for the parameters to be measured allows the sensor to achieve the following:

- High long-term stability,
- virtually linear characteristic,
- good dynamic behaviour,
- dewing resistance,
- low temperature coefficients,
- small hysteresis.

The interface to the device is digital and consists of an RS485 interface in half duplex mode. In conjunction with ID-based communication the interface enables operation of the sensors in a bus system.

Two data protocols are available:

- ASCII (THIES format)
- Binary (MODBUS-RTU)

In addition to the digital interface, the transmitters with article numbers 1.1006.54.x4x and 1.1006.54.x6x have 3 analogue outputs which can be configured as a current or voltage output (see chapter 1.). The digital output can be used simultaneously with the analogue outputs.

Note:

For use outdoors we recommend additionally using a weather and thermal radiation shield. This is can be ordered as an optional accessory. [See 15. Accessories.](#)

3 Setup and Mode of Operation

The sensor is equipped with a built-in pressure sensor, as well as a replaceable hygro-thermo module for the capture of air temperature and relative humidity.

The replaceable hygro-thermo-module and the pressure sensor are factory adjusted and calibrated.

The sensor is supplied without a filter cap. The hygro-module is protected with its own white membrane. The sensor thus offers excellent dynamic behaviour. This protective membrane must not be removed. We offer an additional filter cap for e.g. maritime applications (see 15. Accessories). PT1000 measuring element is used for temperature measurement.

The individual measured values are captured and analysed once a second. The last measured second value is always output. The dew point is calculated internally from the temperature and relative humidity. It is additionally output in the data telegram.

The air pressure sensor is contained inside the housing. Pressure equalisation in relation to the housing interior takes place via the connecting cable and the cable connector, which are not pressure-tight. The air pressure sensor always measures the current absolute air pressure (QFE) present at the installation site. The station height above sea level can be specified using parameter SH to calculate the corrected air pressure at sea level (QNH). The reduced air pressure (QNH) is the air pressure which is given by official bodies (for example meteorological services) for a specific location.

The internal air pressure of the transmitter is equalised via the cable. For this reason, the air pressure is measured from the end of the cable. The air pressure is measured at the height of the transmitter. Pressure fluctuations, for example door closed in an airtight room, are dampened to the greatest possible extent by the long-time constant of over 8s.

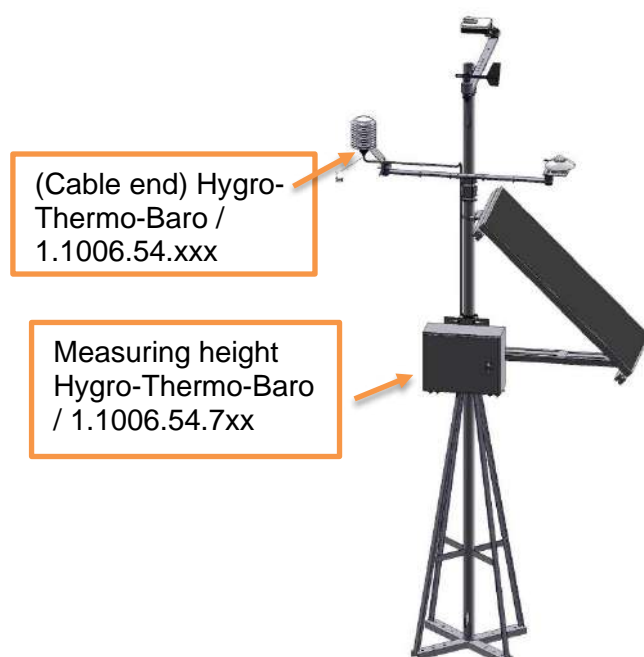

Figure 1: Example Pressure Equalization

4 Recommendation Side Selection / Standard Installation

The Hygro-Thermo-Baro transmitter should be mounted at a location that is representative for climate measurement for meteorological and climatological applications 2m above ground with grass. To protect the sensor from direct sunlight and precipitation it is installed in a weather and thermal radiation shield (see [15. Accessories](#)).

The installation position is fixed when using a weather and thermal radiation shield.

With applications without a weather and thermal radiation shield theoretically any installation position can be selected. The sensor should however be installed to avoid the ingress of water and radiation from the sun. Dewing and splashes of water will not damage the sensor but lead to "wrong" measured values.

It should also be ensured that the operating voltages are observed and that the air circulation around the sensor is good. Any deviations here may influence measured values (e.g., due to self-heating).

If wall-mounted (indoor application), the sensor should preferably be pointing down vertically and with duct installation, horizontally to the rear. In outdoor operation together with suitable weather and radiation protection, the preferred type of mounting is vertically upwards.

5 Installation

Note:

Do not touch the highly sensitive hygro-thermo sensor element on the sensor surface.

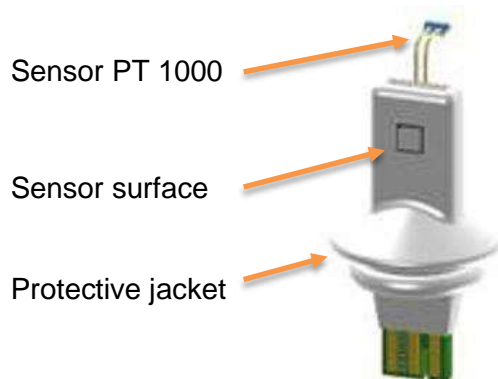

The white protective jacket on the hygro-thermo sensor element must not be removed.

5.1 Electrical Mounting

Note:

The RS485 interface is electrically connected with the supply voltage. Internally the sensor has 2 bias resistors of 47kOhm with RxD +3.3V and Tx D GND.

Pressure equalisation for the pressure sensor takes place via the cable. Please bear this in mind on installation.

5.2 Connection Diagram

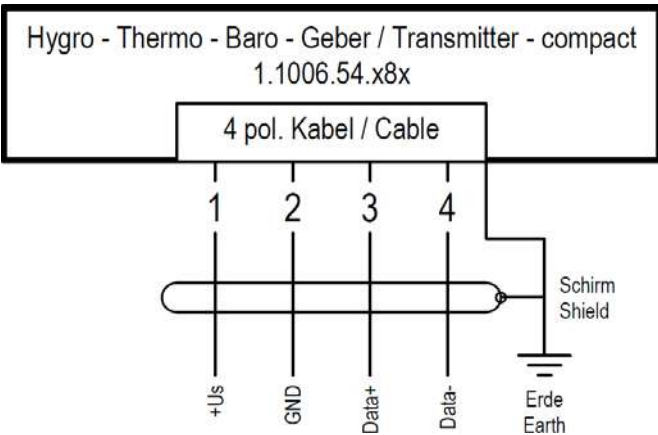
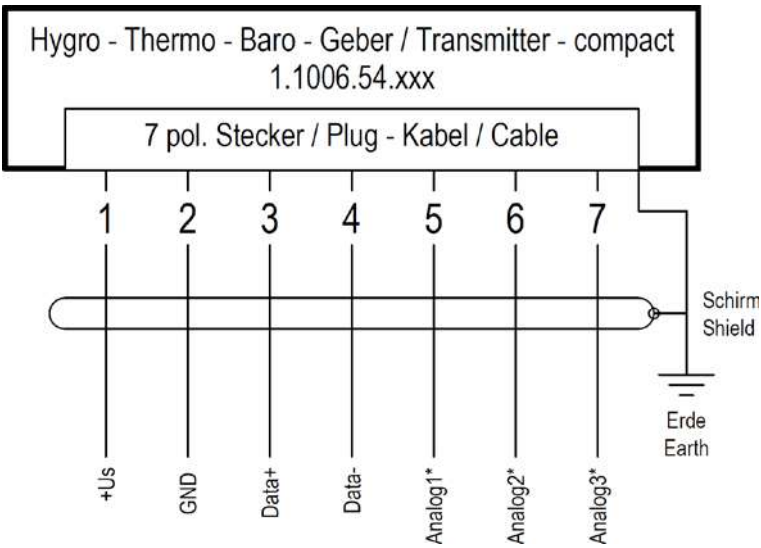
Order – No.	Connection Diagram
1.1006.54.080 1.1006.54.081 1.1006.54.780 1.1006.54.781	
1.1006.54.1xx 1.1006.54.741 1.1006.54.76x	

* Outputs 1 to 3 only have a function with analogue output sensors and are configurable.

5.3 Cable Assignment

Order – No.	PIN	Name	Function	Core colour
1.1006.54.080	1	+Us	Supply voltage	white
1.1006.54.081	2	GND	Ground	brown
1.1006.54.780	3	Data+	RS485 Data + (A)	green
1.1006.54.781	4	Data-	RS485 Data – (B)	yellow
	⏏	Shield	-	green - yellow

Table 1: Cable assignment of the sensor 1.1006.54.x8x

Order – No.	PIN	Name	Function	Core colour
1.1006.54.141	1	+Us	Supply voltage	white
1.1006.54.160	2	GND	Ground	brown
1.1006.54.161	3	Data+	RS485 Data + (A)	green
1.1006.54.741	4	Data-	RS485 Data – (B)	yellow
1.1006.54.760	5	Analogue 1	Abs. air pressure ¹	gray
1.1006.54.761	6	Analogue 2	Rel. humidity ¹	rose
	7	Analogue 3	Airtemperature ¹	blue
	⏏	Shield	-	green - yellow

Table 2: Cable assignment of the sensor 1.1006.54.1xx

5.4 Plug Assignment

Order – No.	PIN	Name	Function	Core color	Connector
1.1006.54.087	2	+Us	Supply voltage	white	Front view plug 
	1	GND	Ground	brown	
	3	Data+	RS485 Data + (A)	green	
	4	Data-	RS485 Data – (B)	yellow	
	5	NC	Not connected	gray	
	6	NC	Not connected	rose	
	7	NC	Not connected	blue	
	8	NC	Not connected	-	
	⏏	Shield	-	green – yellow	

Table 3: Plug assignment of the sensor 1.1006.54.087

¹ The outputs are configurable and may deviate from the descriptions in the tables. QFF and the dew point may also be output. Configuration takes place at the factory and can be queried with the command OL (Output Link). The specified configuration of the analog outputs refers to the parameter OL00134.

Order – No.	PIN	Name	Function	Core color	Mating connector
1.1006.54.78x	1	+Us	Supply voltage	white	View on the soldered joint of the counter plug 
	2	GND	Ground	brown	
	3	Data+	RS485 Data + (A)	green	
	4	Data-	RS485 Data – (B)	yellow	
	5	NC	Not connected	gray	
	6	NC	Not connected	rose	
	7	NC	Not connected	blue	
	⏏	Shield	-	green – yellow	

Table 4: Plug assignment of the sensor 1.1006.54.78x

Order – No.	PIN	Name	Function	Core color	Mating connector
1.1006.54.74x 1.1006.54.76x	1	+Us	Supply voltage	white	View on the soldered joint of the counter plug 
	2	GND	Ground	brown	
	3	Data+	RS485 Data + (A)	green	
	4	Data-	RS485 Data – (B)	yellow	
	5	Analogue 1	Abs. airpressure ¹	gray	
	6	Analogue 2	Rel. humidity ¹	rose	
	7	Analogue 3	Airtemperature ¹	blue	
	⏏	Shield	-	green – yellow	

Table 5: Plug assignment of the sensor 1.1006.54.74x, 1.1006.54.76x

¹⁾The outputs are configurable and may deviate from the descriptions in the tables. QFF and the dew point may also be output. Configuration takes place at the factory and can be queried with the command OL (Output Link). The specified configuration of the analog outputs refers to the parameter OL00134.

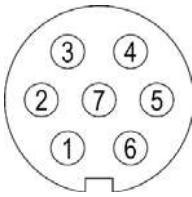
5.4.1 Cable

Order – No.: **1.1006.54.78x**

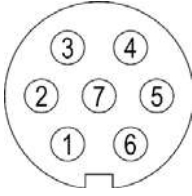
The cable to be connected should have the following properties: 4 cores, core cross-section 0.25mm², cable diameter 3 ... 5mm, resistant to ultraviolet rays, overall shielding.

Order – No.: **1.1006.54.74x, 1.1006.54.76x**

The cable to be connected should have the following properties: 7 cores, core cross-section 0.25mm², cable diameter 5 ... 7mm, resistant to ultraviolet rays, overall shielding.

5.4.2 Cable Shield

The connection of the cable shielding between the sensor and data acquisition system should be selected to prevent compensating currents in the event of overvoltage's and possible de-struction of the electronic components.

The following procedure is recommended for using the cable shield:

Lay the cable shield between the sensor and the data acquisition system (e.g., datalogger) on both sides. Ground the data acquisition system.

5.4.3 Plug and Cable Mounting

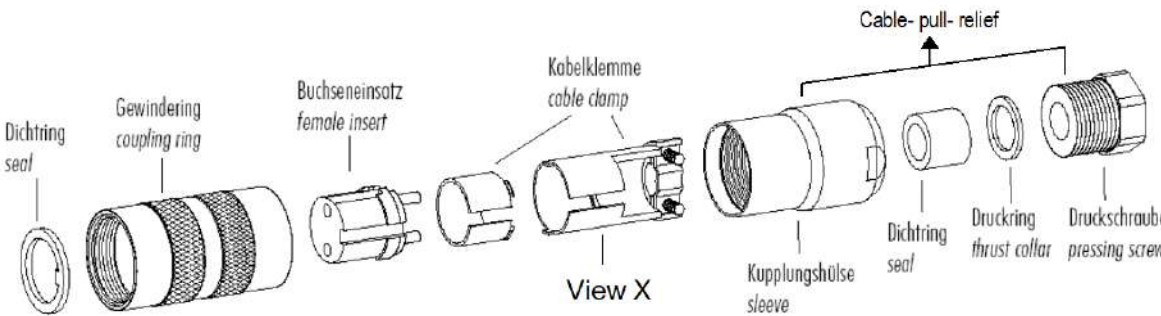
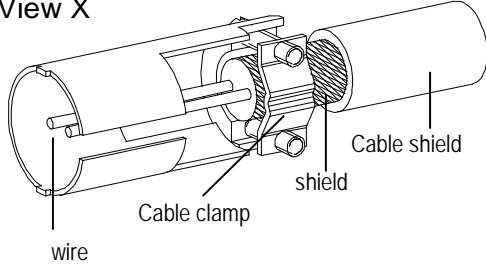
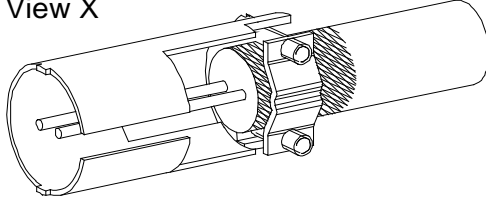
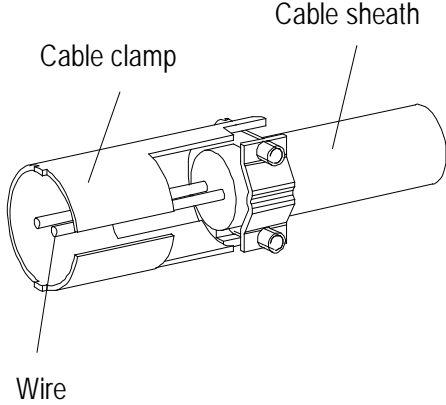
Coupling socket, Type: Binder, Serial 423, EMC with cable clamp	
	
Cable connection: with cable shield	
<ol style="list-style-type: none"> 1. Stringing parts on cable acc. to plan given above. 2. Stripping cable sheath 20mm Cutting uncovered shield 15mm Stripping wire 5mm. <p><i>Cable mounting 1</i> Putting shrink hose or insulating tape between wire and shield.</p> <p><i>Cable mounting 2</i> If cable diameter permits, put the shield backward on the cable sheath.</p> <ol style="list-style-type: none"> 3. Soldering wire to the insert, positioning shield in cable clamp. 4. Screwing-on cable clamp. 5. Assembling remaining parts acc. to upper plan. 6. Tightening pull-relief of cable by screw-wrench (SW16 und 17). 	<p><i>Cable mounting 1</i> View X</p> 
<ol style="list-style-type: none"> 3. Soldering wire to the insert, positioning shield in cable clamp. 4. Screwing-on cable clamp. 5. Assembling remaining parts acc. to upper plan. 6. Tightening pull-relief of cable by screw-wrench (SW16 und 17). 	<p><i>Cable mounting 2</i> View X</p> 
Cable connection: without cable shield	
<ol style="list-style-type: none"> 1. Stringing parts on cable acc. to plan given above. 2. Stripping cable sheath 20mm 3. Cutting uncovered shield 20mm 4. Stripping wire 5mm. 5. Soldering wire to the insert. 6. Positioning shield in cable clamp. 7. Screwing-on cable clamp. 8. Assembling remaining parts acc. to upper plan. 9. Tightening pull-relief of cable by screw-wrench (SW16 und 17). 	

6 Maintenance

The hygro-thermo-baro transmitter is supplied adjusted and calibrated.

Although dust deposits do not damage the humidity sensor, they will impair dynamic behaviour. With very heavy soiling dust can be blown off the hygro-thermo sensor element or it can be carefully rinsed in distilled water. Do not touch the highly sensitive hygro-thermo sensor element on the **sensor surface**.

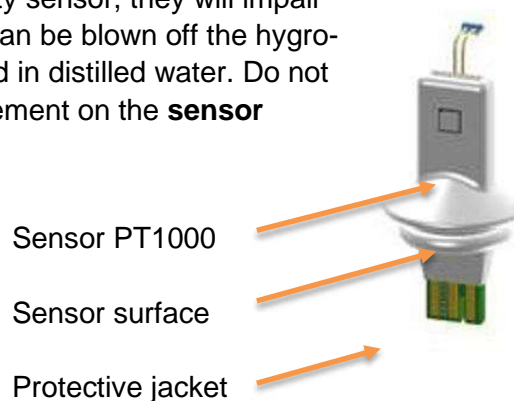

The white **protective jacket** on the hygro-thermo sensor element must not be removed.

Applications with filter cap: The filter cap can be taken off and should also be cleaned or replaced as necessary (see Accessories).

Figure 2: Hygro-thermo Measuring Element

7 Firmware Update

The firmware can be updated using the program "ThiesDeviceUtility" (see also 8 Bootloader). This program can be downloaded from the THIES homepage and installed. The firmware files are directly available from Thies. Firmware updates should only be performed prior to calibration of the sensor.

8 Bootloader

The software in the device consists of 2 components:

- Bootloader
- Firmware

The program part "Bootloader" cannot be changed and is executed first whenever the device starts up. The behaviour of the bootloader depends on the parameter "FB" (Fast Boot):

Command: FB=0

The bootloader waits approx. 10s for the new firmware to be received via XMODEM protocol. The character "C" is output every second. The firmware starts either after the new firmware has been received or at the end of 10s.

Command: FB=1

The bootloader starts the firmware at once.

The protocol XMODEM CRC with a user data length of 128 bytes per packet is used to transfer the firmware. The interface is operated here with 9600baud, 8 data bits, no parity and a stop bit (9600, 8, N, 1).

To assist with parameter settings and / or special configurations, our free Device Utility Tool (Art. No. 9.1700.81.000) is available for download via the following link.

Link: <https://www.thiesclima.com/de/Download>

Program "Thies Device Utility" under heading "General".

9 Analog Output

The analogue output is factory-configurable as a current or voltage output. Transmitters for which the current output or a voltage output with an output voltage greater than 2.5 volt (e.g., 0 ... 10V) is used require an input voltage of at least 15V. The setting of the maximum output signal can be read out with the command OSX. If the supply voltage is too low, the transmitter with current output reports an error and displays 3mA at all 3 outputs, as the maximum output current cannot be attained or accordingly 380 mV as an error value, since the maximum output value cannot be reached.

Three of the following measured values can be output to the three outputs. Configuration takes place on delivery and can be read out with the command OL:

- Absolute air pressure (QFE).
- Reduced air pressure (QNH).
- Relative humidity.
- Air temperature.
- Dew point.

The standard configuration is:

- Analog output 1: absolute air pressure (QFE).
- Analog output 2: relative humidity.
- Analog output 3: air temperature.

With linear conversion of the form $Y = ax + b$, the measured value can be calculated from the output signal (current or voltage). Here Y is the measured value calculated, a is the divided difference, b the offset and x the measured output signal. The offset b is always the lower limit of the measured value, e.g., 600hPa or -40°C.

The divided difference is always the difference of the operating range of the measured value divided by the difference of the output signal.

Example:

Air pressure min: 800hPa
 Air pressure max: 1200hPa
 Output signal min: 0V
 Output signal max: 10V

The difference of the operating range is then: $1200\text{hPa} - 800\text{hPa} = \underline{400\text{hPa}}$

The difference of the output signal is: $10\text{V} - 0\text{V} = \underline{10\text{V}}$.

If the difference of the operating range is divided by the difference of the output signal, resulting in the following calculation: $400\text{hPa} / 10\text{V} = 40\text{hPa/V}$.

This results in the formula:

measured value $Y = 40\text{hPa} \cdot \text{output signal } x + 800\text{hPa}$

This results in the following equations for conversion:

	Air pressure (Output 1) 600hPa...1200hPa	Rel. Humidity (Output 2) 0%...100%	Air temperature (Output 3) -40°C...60°C
0...1V	$p = \frac{600\text{hPa}}{1\text{V}} \cdot U[\text{V}] + 600\text{hPa}$	$F = \frac{100\%}{1\text{V}} \cdot U[\text{V}]$	$T = \frac{100^\circ\text{C}}{1\text{V}} \cdot U[\text{V}] - 40^\circ\text{C}$
0...10V	$p = \frac{600\text{hPa}}{10\text{V}} \cdot U[\text{V}] + 600\text{hPa}$	$F = \frac{100\%}{10\text{V}} \cdot U[\text{V}]$	$T = \frac{100^\circ\text{C}}{10\text{V}} \cdot U[\text{V}] - 40^\circ\text{C}$
4...20mA	$p = \frac{600\text{hPa}}{16\text{mA}} \cdot I[\text{mA}] + 600\text{hPa}$	$F = \frac{100\%}{16\text{mA}} \cdot I[\text{mA}]$	$T = \frac{100^\circ\text{C}}{16\text{mA}} \cdot I[\text{mA}] - 40^\circ\text{C}$

Table 6: Conversion analog outputs

10 Interface

The interface to the sensor consists of an RS485 connection (half duplex mode) with the following interface parameters:

- 9600 baud (the baud rate can be set with Table 7: List of commands
- Command BR).
- 8 data bits.
- No parity.
- 1 stop bit.
- Data in ASCII format (command interpreter: THIES).
- Data in binary format (command interpreter: MODBUS RTU).

The behaviour (configuration) of the HTB sensor can be changed with the commands available (see). With the command interpreter type THIES the measured values are queried with **Command TR**.

If the parameter FB (see **Command FB**) is set to one or zero, the telegram "LL" is output when the sensor starts.

Note:

The start message is output with the baud rate set (see "Command BR") and the data format 8N1 (8 data bits, no parity, 1 stop bit).

The sensor is equipped with a half-duplex interface. If the sensor is set to automatic telegram output, commands can only be sent to the sensor without errors within the first 60 seconds. When commands are sent during independent telegram output, communication errors can occur.

10.1 Command Interpreter THIES

The sensor is equipped with the command interpreter type THIES, which can be used to change the behaviour of the device or query information. It is possible e.g., to change the station height for calculating the reduced air pressure or to query sensor information with the command "LL".

A command basically has the following structure:

- <id><command><CR> (Without parameter: used to query the selected parameter).
- <id><command><parameter><CR> (With parameter: used to set a new parameter)

id: Identification number ("00" to "99")

Command: Command consisting of 2 or 3 characters (see list of commands)

Parameter: Parameter value with 1 to 10 places (decimal value in ASCII format directly following command without blanks)

<CR>: Carriage return (13_{dec}; 0x0D)

The identification number 'id' can be used to operate several devices together in the bus system. Here each device is assigned an individual 'id' (see **Command ID**).

When sent, a command is acknowledged with a corresponding echo telegram. The echo telegram generally begins with "!", followed by the id, the command and the value set. This is followed by the characters "carriage return" and "new line".

The standard response deviates with erroneous commands or commands relating to status queries.

Commands can be sent either with or without parameters. If no parameter is specified, the set value is output.

<i>Example:</i>	00BR<CR>	Send command without parameters
	!00BR00005<CR>	Standard echo telegram
	00EFS<CR>	Send command without parameters
	Fault status:	Echo telegram with error message Vcc too small
	Main board: OK	
	Air pres.: OK	
	Analog output: 0008	
	Satellite: OK	
	I2C: OK	
	EEPROM: OK	
	SHT Humidity: OK	
	RH Humidity: OK	
	SHT35 Temp.: OK	
	PT1000 Temp.: OK	
	Dew point: OK	

If a command is sent with a parameter, the parameter is checked. If the parameter is valid, it is stored and specified in the echo telegram. If the parameter is invalid, it will be ignored and the set value output in the echo telegram. In special cases the standard echo telegram is not output with incorrect parameters, but the special telegram !00CE00008 (Incorrect key) or !00CE00016 (Parameter invalid).

Examples:

00ID00005<CR>	Transmission command.
!05ID00005<CR>	Echo telegram (Parameter valid and password OK).
00ID00004<CR>	Transmission command.
!00ID00000<CR>	Echo telegram (Parameter valid but key incorrect).
00EFS1<CR>	Transmission command.
!00CE00008<CR>	Echo telegram (Parameter valid but key incorrect)
00OL1000<CR>	Transmission command.
!00CE00008<CR>	Echo telegram (parameter incorrect but key correct).

Note:

The measured sensor values can be queried with the command TR. Here the sensor does not respond with the echo telegram, but with the requested data telegram!

To avoid any unintentional change in parameters, some commands (see list of commands) are protected with a password. This password must be transmitted before the actual command.

Example: Change in baud rate

```
00KY1<CR>      Commands releasing the user level
00BR4<CR>      Set baud rate to 4800
!00BR00004<CR> Baud rate set to 4800
```

The sensor supports 3 different password levels:

- User level 0 (standard mode, without password)
- User level 1 (password: "1", for user parameter settings)
- Administrator level
- Calibration level for calibration laboratories

Please note:

Password-protected commands are released as long as one of the following conditions is satisfied:

- *switching of supply voltage*
- *command 00KY0<CR> is sent*
- *no new command is sent for min. 120s*

10.1.1 Telegram Formats

Data output takes place in response to the command TR. Selection between different telegrams is possible. In telegrams 6 and 7 measured values are output with a further place after the decimal point. Telegram 6 should be used to calibrate the sensor.

Calculation of the checksum, composition of the status word and the control characters/separators used in the telegrams are described below.

Control characters:

```
CR – Carriage Return (13dec; 0x0D)
LF – Line Feed (10dec; 0x0A)
STX – Start of Text (2dec; 0x02)
ETX – End of Text (3dec; 0x03)
```

Characters:

The individual measured values in the string are separated by a semicolon ';'. The multiplication sign '*' is used as the check sum separator.

10.1.2 Generation Check Sum:

The check sum is the result of bitwise EXOR linking of the bytes output in the telegram. The EXOR link encompasses all bytes between the telegram start character "STX" and the byte "*" as the identifying character for the start of the check sum. The bytes "STX" and "*" are not taken into account for calculation of the check sum.

10.1.3 Status Information:

In the sensor there is a status word (32bit), which supplies information about the state of the transmitter. The measured values undergo a plausibility check and are displayed in the status word. Please use for more details [Command EFS](#).

Bit number	Function	Description
Bit 0	VCC fault	The supply voltage is < 6 V or > 30V
Bit 1	3V fault	The 3V processor voltage is not OK
Bit 2	Fault pressure sensor	The pressure sensor reports fault
Bit 3	Reserved	Reserved
Bit 4	Reserved	Reserved
Bit 5	Analog output error	Analog hygro-thermo measuring element is in an invalid mode
Bit 6	No hygro-thermo-measuring element	No valid measuring element was detected
Bit 7	Hygro-Thermal Sensor Error	The hygro-thermo-measuring element reports error

Faults 3 - 7 are variant-dependent and only exist if the hardware also exists.

Table 7: Status Word

10.2 Commands and Description

The following table lists the available commands and the corresponding password for read and writing.

Command	Initial value Factory setting	MODBUS Register address	Description	Password	
				Read	Write
BR	96	40005	Baud rate	Without	User
CF	0	-	Calibration Status	Without	-
CI	0/1 ²	40013	Command interpreter	Without	User
FB	1	40001	Quick start	Without	User
HW	-	-	Hardware Configuration	Without	-
ID	0/1 ³	40003	ID-number	Without	User
KY	0	40009	Key / Password	Without	-
LL	-	-	Inquiry of the sensor status	Without	-
OL	134	-	Output configuration of the analog Analog outputs	Without	User
OR	1000	40017	Telegram output interval	Without	User
PO	5000	40025	Air pressure offset	Without	-
RD	20	40019	Response delay	Without	User
RS	-	40021	Reset	Without	User
SF	0	40015	Frame format (RS485)	Without	User
SH	0	40023	Station height	Without	User
SN	-	40007	Serial number	Without	-
TA	-	-	Part number	Without	-
TR	-	-	Telegram query	Without	-
TT	0	-	Automatic telegram query	Without	User
EFS	-	-	Status information of the hygro- thermo measuring element	Without	User
AVN	See factory setting sheet	-	Analog output 1 min. measured value	Without	User
AVX		-	Analog output 1 max. measured value	Without	User
BVN		-	Analog output 2 min. measured value	Without	User
BVX		-	Analog output 2 max. measured value	Without	User
CVN		-	Analog output 3 min. measured value	Without	User
CVX		-	Analog output 3 max. measured value	Without	User
OSN		-	Minimum output value for the ana- log Analog outputs	Without	User
OSX		-	Maximum output value for the an- alog Analog outputs	Without	User

Table 8: List of commands

² The device variant with THIES ACII interpreter is supplied with CI0, the variant with MODBUS RTU with CI1.

³ The device variant with THIES ACII interpreter is supplied with ID0, the variant with MODBUS RTU with ID1. If the sensor contains an additional sticker with the ID, the ID of the sticker is valid.

10.2.1 Command BR

<id>BR<parameter><CR> Set the baud rate

Access: Read / write

Description: The baud rate is set with the command BR

Parameter Type: Unsigned integer

Parameter:

Parameter	Description
12	1200baud
24	2400baud
48	4800baud
96	9600baud
192	19200baud
384	38400baud
576	57600baud

Type return value: unsigned integer

Return value: See parameter

Value range: 1200 / 2400 / 4800 / 9600 / 19200 / 38400 / 57600

Initial value: 9600

10.2.2 Command CF

<id>CF<parameter><CR> Calibration status

Access: Read

Description: The calibration status is queried with the CF command. In the case of calibrated measuring elements, the calibration status is set to one at the factory. When replacing the hygro-thermo measuring element later, the error "invalid replacement of hygro-thermo measuring element" is displayed. Even if the status was not set, the measuring element was adjusted in manufacturing.

Parameter Type: Unsigned integer

Parameter:

Parameter	Description
0	Without calibration
1	With calibration

Type Return value: Unsigned integer

Return value: See parameter

Range of values: 0 bis 1

Initial value: 0

10.2.3 Command CI

<id>CI<parameter><CR> Selection of the command interpreter

Access: Read / write

Description: The command interpreter is set with the command CI.

Note:

If the identification number (ID) is greater than 98, it is automatically set to 0 with switching to the THIES interpreter!

Note:

If the identification number (ID) is 0, switching to the MODBUS-RTU interpreter is not then possible!

Parameter Description:

Parameter	Description
0	THIES
1	MODBUS RTU

Range of values: 0 bis 1

Initial value: 0/1 depending on the device version.

0 with THIES ACII interpreter, 1 with MODBUS RTU

10.2.4 Command FB

<id>FB<parameter><CR> Quick start mode

Access: Read / write

Description: The command is used to select the quick start mode or to query the set mode.

In the quick start modes, the bootloader immediately jumps into the firmware and does not output any data. If the quick start mode is inactive, the bootloader outputs its software version, 9 times the C and the set parameters BR, SF, CI and ID.

In quick start mode 1, the firmware does not output a telegram for the encoder status. In quick start modes 0 and 2, the firmware outputs the "LL" telegram once after the start.

Parameter Type: Unsigned integer

Parameter: 0: Quick start mode off
1: Quick start mode on (without telegram output)
2: Quick start mode on (only telegram LL is sent once)

Type Return value: Unsigned integer

Return value: See parameter

Range of values: 0...2

Initial value: 1

10.2.5 Command HW

<id>ID<parameter><CR>	Hardware configuration
Access:	Read
Description:	The command is used to read out the type of hardware. At the start, the hardware variant and the configuration are read out and checked for plausibility. The result of this plausibility check is read out with this command.
Parameter Type:	Unsigned integer
Parameter:	0: Digital 1: HTB with power output 2: HTB with voltage output 3: Reserved 4: Hardware invalid
Type Return value:	Unsigned integer
Return value:	See parameter
Range of values:	0 ... 4
Initial value:	-

10.2.6 Command ID

<id>ID<parameter><CR>	Identification number
Access:	Read / write
Description:	This command sets the identification number (THIES interpreter) or the slave address (MODBUS RTU interpreter). A response telegram is sent only when the 'ID' in the command matches the one set in the sensor. An exception here is the generic 'ID', to which all sensors respond (THIES interpreter). Once the 'ID' has been changed, the device will immediately respond with the new 'ID'.
Parameter Type:	Unsigned integer
Parameter:	99 generic 'ID' (THIES interpreter) 0 Broadcast slave address (MODBUS RTU interpreter)
Type Return value:	Unsigned integer
Return value:	See parameter
Range of values:	0 bis 99 (THIES Interpreter) 1 bis 247 (MODBUS RTU Interpreter)
Initial value:	0 (THIES Interpreter) für Sensor 1.1006.54.xxx 1 (MODBUS RTU Interpreter) für Sensor 1.1006.54.xx1

10.2.7 Command KY

<id>KY<parameter><CR> Key/password

Access: Read / write

Description: The value for the key (password) is set with this command. The following 2 password levels are possible:

- Query (only read access)
- User (general settings)
- Admin (Thies version configuration)
- Calibration (calibration laboratories)

Parameter Type: Unsigned integer

Parameter:

Parameter	Description
Without	Query = read
1	User
-	Admin (Thies internal)
On request	Calibration for laboratories

Type Return value: Unsigned integer

Return value: See parameter

Range of values: 0, 1, ...

Initial value: 0

10.2.8 Command LL

<id>LL<CR> System status query

Access: Read

Description: System information for the sensor is output with this command.

Type Return value: Text

Return value:

```

Product description:
Hygro-Thermo-Baro-Transmitter COMPACT
Article number      : 1.1006.54.160
PCB number          : 510309
Hardware version    : VER-09-20
Voltage output      : 0.0 - 01.0V
Output link         : 134
Serial number       : 00000000
FW version          : V03.044
Sensor ID           : 00
Thies Interpreter is active
Automatic send of data is disabled.
Fast boot is disabled.

Satellite data:
Article number      : 510481
Hardware version    : VER-01-21
Serial number       : 00AAA00002
END

```

10.2.9 Command OL

<id>OL<parameter><CR> Output configuration (Output Link)

Access: Read

Description: The command reads / write the output configuration of the analogue Analog outputs. It is possible to output different measured values on the analog Analog outputs depending on the type of measuring element. It is possible to output the following measured values:

- 0: Output switched off, not used
- 1: Absolute air pressure (QFE)
- 2: Reduced air pressure (QNH)
- 3: Relative humidity
- 4: Air temperature
- 5: Dew point

The return value has 5 digits, the first two digits are reserved and always 0, the last 3 digits indicate the output configuration for the 3 analog outputs. The first number shows the measured value for analog output 1, the second for analog output 2 and the third for analog output 3. When making an entry, it is sufficient to enter only the 3 digits for the 3 analog channels. The two leading zeros are ignored.

Type of return value: Integer without a leading sign

Return value: 00111 ... 00555

Description: 00: reserved, always 0

The three figures for the 3 analogue outputs may assume the values 1 ... 5 and are linked to the above measured values. With the initial value the number 1 indicates that analogue output 1 outputs the absolute air pressure. The number 3 indicates that the relative humidity is output at output 2 and the air temperature at output 3.

Initial value: 00134

10.2.10 Command OR

<id>OR< parameter > Telegram output interval (Output Rate)
 Access: User mode
 Description: With independent telegram output this parameter is used to specify the time interval in which telegrams are output via the serial interface. Specification is in milliseconds. If the output speed is higher than the data can be transmitted, the available output is discarded.
 If the output is faster than acquisition of the measured values, the measured values available are output again.
 The parameter OR does not influence data acquisition; the internal sampling rate of the data is fixed to 1 second.
 See also **Command TT**.

ParameterDescription:

0: → A telegram is always output when internal measured value acquisition has calculated a new data set.

1...60000 → Specifies the output interval in milliseconds.

Range of values: 0...60000 [ms]

Initial value: 1000

10.2.11 Command PO

<id>PO<parameter><CR> Air pressure offset
 Access: Read
 Description: The pressure offset is reset with this command. The pressure offset is selected with adjustment of the sensor on initial start-up.
 The parameter / return value has an offset of 5000 related to the offset of the transmitter. An increase or decrease in the parameter of +/-1 results in an offset correction of +/-0.01hPa.

Query (only read access)

Type Return value: Integer

Description: 4900 -> -1hPa

5000 -> 0hPa

5100 -> +1hPa

The following applies: output value = measured value + offset

Range of values: 4000 ... 6000

Initial value: 5000

10.2.12 Command RD

`<id>RD<parameter>` Delayed response (Response Delay)
 Access: Read / write
 Description: With this command the response is delayed by the time specified in ms following a command via the serial interface
 Range of values: 0 ... 1000
 Initial value: 20
 Unit: ms

10.2.13 Command RS

`<id>RS<parameter><CR>` Reset
 Access: Read / write
 Description: The command RS is used to query the reset source (read without parameter) or to perform reset/restart (write with parameter). Write with a parameter returns a standard response with a parameter value without a leading sign. Read gets back a text stream with the reset source.

The following reset sources can be output:

BOR	(Power On Reset Flag)
EXT	(External Reset Flag)
BODCORE	(Brownout Detection Core)
BODVDD	(Brownout Detection Power Supply)
WDT	(Watchdog Reset Flag)
SYST	(System Reset)
invalid	(all other cases)

Parameter Type: Unsigned integer
 Parameter: 1 Watchdog Reset
 2 Software Reset
 Type Return value: Integer without a leading sign or text stream (see Description)
 Return value: Parameter or text stream
 Range of values: 1 / 2
 Initial value: -

10.2.14 Command SF

<id>SF<parameter><CR>	Frame format
Access:	Read / write
Description:	The frame format of the interface is set with the command SF
Parameter Type:	Unsigned integer
Parameter:	0: 8N1 (8 data bits, no parity, 1 stop bit) 1: 8N2 (8 data bits, no parity, 2 stop bits) 2: 8E1 (8 data bits, even parity, 1 stop bit) 3: 8E2 (8 data bits, even parity, 2 stop bits) 4: 8O1 (8 data bits, odd parity, 1 stop bit) 5: 8O2 (8 data bits, odd parity, 2 stop bits) 6: 7E1 (7 data bits, even parity, 1 stop bit) 7: 7N1 (7 data bits, no parity, 1 stop bit)
Type Return value:	Unsigned integer
Return value:	See parameter
Range of values:	0 ... 7
Initial value:	0

10.2.15 Command SH

<id>SH<parameter><CR>	Station height
Access:	Read / write
Description:	<p>The station height at the sensor site is set with this command. This value is used to calculate the reduced air pressure. The height is specified in metres.</p> <p>It is necessary to specify the station height to calculate the reduced air pressure at sea level. If the station height is 0m, the value output for the reduced air pressure and the absolute air pressure are identical.</p>
Parameter Type:	Unsigned integer
Parameter:	Height above sea level in metres -500 ... 10000: station height in metres. Basis for calculating the reduced air pressure
Type Return value:	Unsigned integer
Return value:	See parameter
Range of values:	-500 ... 10000
Initial value:	0

10.2.16 Command SN

<id>SN<parameter><CR> Serial number
Access: Read
Description: The command enables the serial number to be read.
Parameter Type: -
Parameter: -
Type Return value: Unsigned integer
Return value: xxxxxxxxxx: serial number
Range of values: xxxxxxxxxx
Initial value: -

10.2.17 Command TA

<id>TA<parameter><CR> Thies part number
Access: Read
Description: Returns the article number with the hardware version. The article number is queried with Parameter 1 and Parameter 2, e.g. 00TA1 and 00TA2.
Query (only read access)
Type Return value: Unsigned integer
Return value: 00TA11006
00TA54080
Together, this results in the article number
1.1006.54.080

10.2.18 Command TR

<id>TR<parameter><CR>	Measured value request
Access:	Read
Description:	The command initiates one-off transmission of the current data telegram.
Parameter Type:	Unsigned integer
Parameter:	1: Query measured value telegram 1 2: Query measured value telegram 2 3: Query measured value telegram 3 4: Query measured value telegram 4 5: Query measured value telegram 5 6: Query measured value telegram 6 7: Query measured value telegram 7
Type Return value:	Character string
Return value:	Character string (see Telegram)
Range of values:	1 ... 7
Initial value:	-

10.2.19 Command TT

<id>TT<parameter>	Independent telegram output (Telegram Transmission)
Access:	User mode
Description:	Specifies the number of the telegram that the ULTRASONIC transmits independently on a cyclic basis. The same telegrams are available as described under Command TR . To switch off independent telegram output, the parameter of TT must be set to 0.
Type Return value:	Character string
Return value:	See Telegram
Range of values:	0 ... 7
Initial value:	0

Note:

The sensor is equipped with a half duplex interface. If the sensor is set to automatic telegram output, commands can only be sent to the sensor without errors within the first 60 seconds. When commands are sent during independent telegram output, communication errors can occur.

10.2.20 Command EFS

<id>EFS<parameter><CR> Status of the sensor (Extended Fault Status)

Access: Read

Description: The command returns the status of the Hygro-Thermo-Baro transducer. For each module of the Hygro-Thermo-Baro-Transducer the telegram sends a line with the name of the module and followed by the status. If a module is error-free, an OK is returned. Otherwise, the error code is returned. The telegram output depends on the variant. In the case of digital variants, for example, analog output is not output.

Parameter Type: -

Parameter: -

Type Return value: Character string

Return value: Status in hexadecimal form or OK

Sample answer:

Example answer:	Fault status:
Main board:	OK
Air pres.:	OK
Analog output:	0008
Meas. element:	OK
I2C:	OK
EEPROM:	OK
SHT Humidity:	OK
RH Humidity:	OK
SHT35 Temp.:	OK
PT1000 Temp.:	OK
Dew point:	OK

Error code description:

Mainboard error:

Bit 0: Vcc error, voltage in invalid range

Bit 1: 3v μ C internal voltage error

Air pressure sensor error (only if air pressure measurement is active):

Bit 0: Chip ID error

Bit 1: Calculation error during initialization

Bit 2: Calculation error in measurement mode

Bit 3: Status bytes read wrong

Bit 4: Wrong number of bytes read

Bit 5: Air pressure invalid value range.

Bit 6: Temperature invalid range of values.

Bit 7: Sensor switched off

Analog output error (only for hardware with analog output):

- Bit 0: Initialization error
- Bit 1: Output parameters Ymin or Ymax invalid
- Bit 2: Mode error, hardware and parameters do not match
- Bit 3: Vcc too small (< 15V for current or 0 ... 10V output value range)
- Bit 4: Output link (OL) parameter too large (> 999)
- Bit 5: Outbound link (OL) parameter cannot be decoded
- Bit 6: Module in invalid mode
- Bit 7: Output 1 parameters in invalid range
- Bit 8: Output 2 parameters in invalid range
- Bit 9: Output 3 parameters in invalid range
- Bit 10: Input value for output 1 is invalid
- Bit 11: Input value for output 2 is invalid
- Bit 12: Input value for output 3 is invalid

Measuring element error (satellite):

- Bit 0: Module initialization error
- Bit 1: I2C error
- Bit 2: EEPROM read error
- Bit 3: EEPROM Page1 invalid
- Bit 4: Module mode error
- Bit 5: Sensor error
- Bit 6: unknown measuring element

I2C bus error:

- Bit 0: I2C activation error
- Bit 1: I2C write error
- Bit 2: I2C read error

EEPROM error:

- Bit 0: Module initializes but no valid measured value available
- Bit 1: CRC error
- Bit 2: Read error
- Bit 3: Write error
- Bit 4: Reading mirrored area failed
- Bit 5: Error writing to mirrored area
- Bit 6: Wrong address
- Bit 7: Value range error
- Bit 8: Free
- Bit 9: Item number wrong
- Bit 10: Sensor ID error
- Bit 11: Write request error
- Bit 12: no measuring element
- Bit 13: Pages have been fixed

SHT35 temperature and humidity errors:

- Bit 0: Measured value initialized but not yet a valid measured value
- Bit 1: Timed out writing
- Bit 2: Timed out reading
- Bit 3: CRC error
- Bit 4: calculation error
- Bit 5: Diagnostic mode, measurement invalid
- Bit 6: Calibration value invalid
- Bit 7: Invalid self-calibration parameter (humidity only)
- Bit 8: Initialization error 2
- Bit 9: Calculation error 2

moisture correction error:

- Bit 0: Module initialised, no valid measured value available yet.
- Bit 1: Incorrect humidity input value
- Bit 2: Input value sensor temperature faulty
- Bit 3: Incorrect air temperature input value
- Bit 4: calculated temperature too small
- Bit 5: Table index too large
- Bit 6: calculated humidity < 0%
- Bit 7: calculated humidity > 100%

PT1000 Modul Fehler:

- Bit 0: Module initialised, no valid measured value available yet.
- Bit 1: Initialization "shut down" error
- Bit 2: Wake up failed
- Bit 3: Start measurement failed
- Bit 4: Get reading failed
- Bit 5: Shut down failed
- Bit 6: Calculation failed
- Bit 7: free
- Bit 8: wrong mode
- Bit 9: Failed to read parameters
- Bit 10: Gain parameter invalid
- Bit 11: Invalid parameter offset

Dew point calculation error:

- Bit 0: Module initialised, no valid measured value available yet.
- Bit 1: Input value humidity invalid
- Bit 2: Input value temperature invalid
- 0xFFFF -> Query error, parameters of called function not valid.

10.2.21 Command AVN

<id>AVN<parameter><CR> Lower limit for the measured value at analogue output 1

Access: Read / write

Description: The command specifies the lower limit of the value to be measured at analogue output 1 with the lowest output signal, e.g. 800hPa with output voltage 0 volt.

The parameter has an offset of 30000. To calculate the parameter to be entered, the required limit value must be added to 30000. For example, 30800 must be entered for 800hPa. With negative numbers e.g. -40°C, 40 must be deducted from 30000 and 29960 thus entered.

At analogue output 1 the default is output of the absolute air pressure. However, it is possible to output another measured value on the Analog output (see here **Command OL**).

Parameter Type: Unsigned integer

Parameter: See factory setting (included in the package)

Return value: As parameter

Initial value: 30800

10.2.22 Command AVX

<id>AVX<parameter><CR> Upper limit for the measured value at analogue output 1

Access: Read / write

Description: The command specifies the upper limit of the of the value to be measured at analogue output 1 with the highest output signal, e.g. 1200hPa with output current 20mA.

The parameter has an offset of 30000. To calculate the parameter to be entered, the required limit value must be added to 30000. For example, 31200 must be entered for 1200hPa. With negative numbers e.g. -40°C, 40 must be deducted from 30000 and 29960 therefore entered.

At analogue output 1 the default is output of the absolute air pressure. However, it is possible to output another measured value on the Analog output (see here **Command OL**).

Parameter Type: Unsigned integer

Parameter: 29920 ... 31200

Return value: As parameter

Initial value: See factory setting (included in the package)

10.2.23 Command BVN

<id>BVN<parameter><CR> Lower limit for the measured value at analogue output 2

Access: Read / write

Description: The command specifies the lower limit of the value to be measured at analogue output 2 with the lowest output signal, e.g. 0% rel. hum. with output voltage 0 volt.

The parameter has an offset of 30000. To calculate the parameter to be entered, the required limit value must be added to 30000. For example, 30800 must be entered for 800hPa. With negative numbers e.g. -40°C, 40 must be deducted from 30000 and 29960 therefore entered.

At analogue output 2 the default is output of the relative humidity. However, it is possible to output another measured value on the Analog output (see here **Command OL**).

Parameter Type: Unsigned integer

Parameter: 29920 ... 31200

Return value: As parameter

Initial value: See factory setting (included in the package)

10.2.24 Command BVX

<id>BVX<parameter><CR> Upper limit for the measured value at analogue output 2

Access: Read / write

Description: The command specifies the upper limit of the value to be measured at analogue output 2 with the highest output signal, e.g. 100% rel. hum. with output current 20mA.

The parameter has an offset of 30000. To calculate the parameter to be entered, the required limit value must be added to 30000. For example, 30100 must be entered for 100% rel. hum. With negative numbers e.g. -40°C, 40 must be deducted from 30000 and 29960 therefore entered.

At analogue output 2 the default is output of the relative humidity. However, it is possible to output another measured value on the Analog output (see here **Command OL**).

Parameter Type: Unsigned integer

Parameter: 29920 ... 31200

Return value: As parameter

Initial value: See factory setting (included in the package)

10.2.25 Command CVN

<id>CVN<parameter><CR> Lower limit for the measured value at analogue output 3

Access: Read / write

Description: The command specifies the lower limit of the value to be measured at analogue output 3 with the lowest output signal, e.g. -40°C with output voltage 0 volt.

The parameter has an offset of 30000. To calculate the parameter to be entered, the required limit value must be added to 30000. For example, 30800 must be entered for 800hPa. With negative numbers e.g. -40°C, 40 must be deducted from 30000 and 29960 therefore entered.

At analogue output 3 the default is output of the air temperature. However, it is possible to output another measured value on the Analog output (see here **Command OL**).

Parameter Type: Unsigned integer

Parameter: 29920 ... 31200

Return value: As parameter

Initial value: See factory setting (included in the package)

10.2.26 Command CVX

<id>CVX<parameter><CR> Upper limit for the measured value at analogue output 3

Access: Read / write

Description: The command specifies the upper limit of the value to be measured at analogue output 3 with the highest output signal, e.g. 60°C with output current 20mA.

The parameter has an offset of 30000. To calculate the parameter to be entered, the required limit value must be added to 30000. For example, 30060 must be entered for 60°C. With negative numbers e.g. -40°C, 40 must be deducted from 30000 and 29960 therefore entered.

At analogue output 3 the default is output of the air temperature. However, it is possible to output another measured value on the Analog output (see here **Command OL**).

Parameter Type: Unsigned integer

Parameter: 29920 ... 31200

Return value: As parameter

Initial value: See factory setting (included in the package)

10.2.27 Command OSN

<id>OSN<parameter><CR> Min. value output signal (Output Signal Min)
Access: Read / write
Description: The command reads / writes the lower limit of the output current / output voltage, e.g. 4mA or 0 volt. The parameter / return value is the lower limit multiplied by a factor of 10, e.g. 40 for 4mA.
Parameter Type: Unsigned integer
Parameter: 0, 40
Type Return value: Unsigned integer
Return value: 0, 40
Description: As parameter
Initial value: See factory setting (included in the package)

10.2.28 Command OSX

<id>OSX<parameter><CR> Max. value output signal (Output Signal Max)
Access: Read / write
Description: The command reads / writes the upper limit of the output current / output voltage, e.g. 20mA or 10 volt. The parameter / return value is the upper limit multiplied by a factor of 10, e.g. 200 for 20mA.
Parameter Type: Unsigned integer
Parameter: 10 ... 100, 200
Type Return value: Unsigned integer
Return value: 10 ... 100, 200
Description: As parameter
Initial value: See factory setting (included in the package)

10.3 Command Interpreter MODBUS RTU

If the MODBUS RTU command interpreter is selected, the transferred bytes are interpreted according to the MODBUS specification (<http://www.modbus.org/>). The sensor represents a MODBUS slave here.

Data transfer takes place in packets known as frames, max. 256 bytes in size. Each packet contains a 16bit CRC checksum (Initial value: 0xffff).

Slave address	Functional code	Data	CRC	
1byte	1byte	0 ... 252 byte(s)	2Bytes	
			CRC low-byte	CRC high-byte

Table 9: MODBUS Frame

The following MODBUS functions are supported:

- 0x04 (Read Input Register).
- 0x03 (Read Holding Registers).
- 0x10 (Write Multiple Registers).
- 0x2B (Read Device Identification with MEI-Type 0x0E).

The wind transmitter supports writing accesses for the slave address 0 ("broadcast").

All MODBUS requests received are checked for validity prior to execution. In the event of an error the sensor responds with one of the following exceptions (→MODBUS Exception Responses):

Code	Name	Meaning
0x01	ILLEGAL FUNCTION	The functional code in the request is not admissible for the register address.
0x02	ILLEGAL DATA ADDRESS	The register address in the request is not valid.
0x03	ILLEGAL DATA VALUE	The specified data in the request is not admissible.

Table 10: MODBUS Exceptions

10.3.1 Measured Values (Input Register)

All measured values of the sensor occupy 32bit, i.e. 2 MODBUS register addresses. The following table shows assignment of the measured value to an register address, with the measured values being sorted as given below:

- According to measured value Type (30001 to 34999).
- In uninterrupted sequence (35001 to 39999).

Register address	Parameter name	Unit	Multiplier	Explanation	Data Type
30401	Air temperature (35007) ¹	°C	10	Value / 10 (1 Decimal place, e.g. 255=25.5°C)	S32
30601	Rel. humidity (35005) ¹	%r.F.	10	Value / 10 (1 Decimal place, e.g. 355=35.5%r.F.)	U32
30605	Dew point temperature (35009) ¹	°C	10	Value / 10 (1 Decimal place, e.g. 115=11.5°C)	S32
30801	Absolute air pressure (QFE) (Unit: hPa) (35001) ¹	hPa	10	Value / 10 (1 Decimal place, e.g. 10500=1050.0hPa)	U32
30803	Reduced air pressure (QNH) (Unit: hPa) (35003) ¹	hPa	10	Value / 10 (1 Decimal place, e.g. 10500=1050.0hPa)	U32
Complete sequence of the measured values at start of 35001					
35001	Absolute air pressure (QFE) (Unit: hPa) (30801)	hPa	10	Value / 10 (1 Decimal place, e.g. 10500=1050.0hPa)	U32
35003	Reduced air pressure (QNH) (Unit: hPa) (30803)	hPa	10	Value / 10 (1 Decimal place, e.g. 10500=1050.0hPa)	U32
35005	Rel. humidity (30601)	%r.F.	10	Value / 10 (1 Decimal place, e.g. 355=35.5%r.F.)	U32
35007	Air temperature (30401)	°C	10	Value / 10 (1 Decimal place, e.g. 255=25.5°C)	S32
35009	Dew pointtemperatur (30609)	°C	10	Value / 10 (1 Decimal place, e.g. 115=11.5°C)	S32
35011	Sensorstatus			Sensor status, see chapter 10.1.3	

Table 11: MODBUS Input Register

¹⁾ The numbers in brackets indicate the register addresses which represent the same measured values. So is the Air temperature for example.is at both address 30401 and address 35007.

Note:

Continuous ordering of the measured values from address 35001 allows the MODBUS master to read out all measured values with a single request.

10.3.2 Commands (Holding Register)

All commands of the sensor occupy 32bit, i.e. 2 MODBUS register addresses and represent integers without a leading sign. The following example shows a change in the baud rate to 19200 baud.

1. Set password for the user level (KY=1)

Slave address	Functional code	Start address	Number register	Number byte(s)	Data	CRC	
0x01	0x10	0x9C 49	0x00 02	0x04	0x00 00 00 01	0x0F 33	
						CRC low-byte	CRC high-byte

2. Set command baud rate to 19200 baud (BR=6)

Slave address	Functional code	Start address	Number register	Number byte(s)	Data	CRC	
0x01	0x10	0x9C 45	0x00 02	0x04	0x00 00 00 C0	0xCE F6	
						CRC low-byte	CRC high-byte

The commands available for parameter setting are listed in the chapter 10.2 commands and description.

10.3.3 Device detection (Read Device Identification)

The sensor supports the MODBUS function 0x2B (Read Device Identification) with the MEI type 0x0E. This allows the MODBUS master to automatically recognise the sensor Function: 0x2B / 0x0E (Read Device Identification).

MEI Type: 0x0E
 Read Device ID code: 1, 2, 3 (stream access)
 Supported objects:

Objekt-Id	Object name / description	Type	Category	Value ^{1,2}
0x00	Vendorname	ASCII String	Basic	"Adolf Thies GmbH &CO. KG"
0x01	Product - Code	ASCII String		1.1006.x4.xxx
0x02	Firmware version	ASCII String		e.g. "V03.06"
0x03	VendorUrl	ASCII String	Regular	"www.thiesclima.com"
0x04	Productname	ASCII String		"Hygro-Thermo-Baro-Sensor"
0x05	Modellname	ASCII String		
0x80	HW-ID ³	ASCII String	Extended	"!00HW01"

Table 12: Device identifier

- ¹⁾ The maximum length of a value can be 32 bytes.
- ²⁾ The quotation marks are not part of the character string.
- ³⁾ The HW ID (object ID: 0x80) consists of 22 bytes, which represent 11 binary bytes.

11 Data Telegrams

11.1 Telegram 1

The sensor responds to the command "00TR1 \ r" with the measured value telegram. The telegram structure is shown in the following table:

Position	Length	Sample	Description
1	1	STX	Start sign (start of text).
2	2	xx	Identification number (ID) xx: 0 ... 99
4	1	;	Separation sign (';')
5	6	1002.3	Absolute air pressure (QFE)
11	1	;	Separation sign (';')
12	6	1014.5	Reduced air pressure at sea level, (QNH) (see command SH)
18	1	;	Separation sign (';')
19	4	0000	Sensor status (see status information)
23	1	*	Checksum identifier (*)
24	2	xy	Exclusive or linked checksum in hexadecimal representation x: high nibble checksum in HEX y: low nibble checksum in HEX
26	1	CR	Carriage return
27	1	LF	Line feed
28	1	ETX	End of text

Table 13: Measured value Telegram 1

11.2 Telegram 2

The sensor responds to the command "00TR2 \ r" with the Measured value telegram. The telegram structure is shown in the following table:

Position	Length	Sample	Description
1	1	STX	Start sign (start of text).
2	2	xx	Identification number (ID) xx: 0 ... 99
4	1	;	Separation sign (';')
5	6	1002.3	Absolute air pressure (QFE)
11	1	;	Separation sign (';')
12	6	1014.5	Reduced air pressure at sea level, (QNH) (see command SH)
18	1	;	Separation sign (';')
19	5	045.3	Rel. humidity
24	1	;	Separation sign (';')
25	5	+24.3	Air temperature
30	1	;	Separation sign (';')
31	4	0000	Sensor status (see status information)
35	1	*	Checksum identifier (*)
36	2	xy	Exclusive or linked checksum in hexadecimal representation x: high nibble checksum in HEX y: low nibble checksum in HEX
38	1	CR	Carriage return
39	1	LF	Line feed
40	1	ETX	End of text

Table 14: Measured Value-Telegram 2

11.3 Telegram 3

The sensor responds to the command "00TR3 \ r" with the Measured value telegram. The telegram structure is shown in the following table:

Position	Length	Sample	Description
1	1	STX	Start sign (start of text).
2	2	xx	Identification number (ID) xx: 0 ... 99
4	1	;	Separation sign (';')
5	6	1002.3	Absolute air pressure (QFE)
11	1	;	Separation sign (';')
12	6	1014.5	Relative air pressure at sea level, (QNH) (see command SH)
18	1	;	Separation sign (';')
19	5	045.3	Rel. humidity
24	1	;	Separation sign (';')
25	5	+24.3	Air temperature
30	1	;	Separation sign (';')
31	5	+03.4	Dew point
36	1	;	Separation sign (';')
37	5	011.5	Abs. humidity
42	1	;	Separation sign (';')
43	4	0000	Sensor status (see status information)
47	1	*	Checksum identifier (*)
49	2	xy	Exclusive or linked checksum in hexadecimal representation x: high nibble checksum in HEX y: low nibble checksum in HEX
50	1	CR	Carriage return
51	1	LF	Line feed
52	1	ETX	End of text

Table 15: Measured value-Telegram 3

11.4 Telegram 4

The sensor responds to the command "00TR4 \ r" with the Measured value telegram. The telegram structure is shown in the following table:

Position	Length	Sample	Description
1	1	STX	Start sign (start of text).
2	2	xx	Identification number (ID) xx: 0 ... 99
4	1	;	Separation sign (';')
5	6	1002.3	Absolute air pressure (QFE)
11	1	;	Separation sign (';')
12	6	1014.5	Relative air pressure at sea level, (QNH) (see command SH)
18	1	;	Separation sign (';')
19	5	045.3	Rel. humidity
24	1	;	Separation sign (';')
25	5	+24.3	Air temperature
30	1	;	Separation sign (';')
31	5	+03.4	Dew point
36	1	;	Separation sign (';')
37	5	011.5	Abs. humidity
42	1	;	Separation sign (';')
43	7	05.1810	Measured supply voltage
50	1	;	Separation sign (';')
51	7	03.3110	Measured 3.3V supply voltage
58	1	;	Separation sign (';')
59	4	0000	Sensor status (see status information)
63	1	*	Checksum identifier (*)
64	2	xy	Exclusive or linked checksum in hexadecimal representation x: high nibble checksum in HEX y: low nibble checksum in HEX
66	1	CR	Carriage return
67	1	LF	Line feed
68	1	ETX	End of text

Table 16: Measured Value-Telegram 4

11.5 Telegram 5

The sensor responds to the command "00TR5\r" with the Measured value telegram. The telegram outputs the measured information in plain text:

```

Sensor ID:                00
Air pressure:             0986.6hPa
QNH:                     1012.6hPa
Humidity:                 047.4%rel.H.
Temperature:              +25.4deg.C
Dew point:                +13.4deg.C
absolute Humidity:        011.2g/m^3
Voltage Vcc:              22.278V
Voltage 3.3V:             3.407V
Hardware version:         VER-07-22
Sensor Status:            0000
  
```

11.1 Telegram 6

The sensor responds to the command "00TR6\r" with the measured value telegram. The telegram gives the measured values with a further place after the decimal point and should be used to calibrate the sensor. The telegram structure is shown in the following table:

Position	Length	Sample	Description
1	1	STX	Start sign (start of text).
2	2	xx	Identification number (ID) xx: 0 ... 99
4	1	;	Separation sign (';')
5	7	1002.34	Absolute air pressure (QFE)
12	1	;	Separation sign (';')
13	5	045.3	Rel. humidity
18	1	;	Separation sign (';')
19	6	+24.34	Air temperature
25	1	;	Separation sign (';')
26	4	0000	Sensor status (see status information)
30	1	*	Checksum identifier (*)
31	2	xy	Exclusive or linked checksum in hexadecimal representation x: high nibble checksum in HEX y: low nibble checksum in HEX
33	1	CR	Carriage return
34	1	LF	Line feed
35	1	ETX	End of text

Table 17: Measured Value-Telegram 6

11.2 Telegram 7

The sensor responds to the command "00TR7r" with the measured value telegram. The telegram specifies the measured values with a further place after the decimal point. The telegram structure is shown in the following table:

Position	Length	Sample	Description
1	1	STX	Start sign (start of text).
2	2	xx	Identification number (ID) xx: 0 ... 99
4	1	;	Separation sign (';')
5	7	1002.34	Absolute air pressure (QFE)
8	1	;	Separation sign (';')
9	7	1002.34	reduced air pressure at sea level, (QNH) (see command SH)
16	1	;	Separation sign (';')
17	5	045.3	Rel. humidity
22	1	;	Separation sign (';')
23	6	+24.34	Air temperature
29	1	;	Separation sign (';')
30	6	+03.45	Dew point
36	1	;	Separation sign (';')
41	5	011.5	Abs. humidity
46	1	;	Separation sign (';')
47	4	0000	Sensor status (see status information)
51	1	*	Checksum identifier (*)
52	2	xy	Exclusive or linked checksum in hexadecimal representation x: high nibble checksum in HEX y: low nibble checksum in HEX
54	1	CR	Carriage return
55	1	LF	Line feed
56	1	ETX	End of text

Table 18: Measured Value-Telegram 7

12 Technical Data

Relative Humidity			
Measuring range	0 ... 100% rel. Humidity		
Accuracy	Typ. $\pm 1,5\%$ r. H. @ 25°C and < 80% r. H. 1,5 % r. H. over the complete measuring range		
Long-term stability	Typ. < 0,25 rel. humidity / year		
Setting time ¹	≤ 10 sec		
Absolute Humidity			
Accuracy ²	Better than $\pm 0,15$ g/m ³ @ -40 ... -20 °C Better than 6 % of measuring @ -20 ... +60 °C		
Air temperature			
Measuring range	-40 ... +85°C		
Accuracy	$\pm 0,1$ °C @ -40 ... +85°C @ moved air > 2 m/s		
Long-term stability	Max. $\leq 0,03$ °C / Year		
Setting time ¹	≤ 20 sec		
Dew point temperature			
Accuracy ²	Better than $\pm 2,0$ °C @ 10 ... 100% rel. humidity, -40 ... 60 °C		
Barometric pressure			
Measuring range	300 ... 1200 hPa		
Accuracy	$\pm 0,25$ hPa @ -20 ... +80°C @ 800 ... 1100hPa $\pm 0,50$ hPa @ -20 ... +80°C @ 600 ... 800hPa		
Long-term stability	$\pm 0,3$ hPa / Year		
Setting time ¹	≤ 8 s with 5m cable length, ≤ 15 s with 50m cable length		
Electrical output			
See 1. Models	RS 485 HD; 0 ... 1 V; 0 ... 10 V; 4 ... 20mA		
Serial interface	Type	RS485	
	Operating mode	Half duplex mode	
	Data format	8N1	
	Baud rate	2400, 4800, 9600, 19200, 38400, 57600	
Resolution (Telegram and interpreter dependent)	Air pressure:	0,01hPa (max.)	
	Humidity:	0,1% rel. humidity	
	Temperature:	0,01°C (max.)	
Accuracy	See above		
Analogue	0 ... 1V @ U _B >6V	0 ... 10V @ U _B >15V	4 ... 20mA @ U _B >15V
	Resolution	16Bit	16Bit
Accuracy	See above	See above	See above
Analogue numbers	3, freely configurable		
Electric supply for electronic	Voltage: 6 ... 30V DC		
Power consumption	See 12.1 Power consumption		

Further information	
Cable with 1.1006.54.78x Cable with 1.1006.54.74x ; 1.1006.54.76x	LiYCY 4 x 0.25mm ² shielded, UV-resistant LiYCY 7 x 0.25mm ² shielded, UV-resistant
Type of connection	See 1. Models
Admissible environmental conditions	-40 ... +85°C 0 ... 100rel. humidity, including condensation
Dimensions	See 13. and 14. Dimensional drawing
Weight	Approx. 0.45kg
Type of protection	IP 67 (applies to the total sensor)
Housing material	Stainless steel

1) Tau63%

2) Derived from the accuracies of humidity and air temperature.

12.1 Power consumption

Type Out-put	RS485	0 ... 1 V	0 ... 10V	0 ... 20mA	Power [mW] at supply voltage from:				
					6V	12V	15V	24V	30V
Supply voltage :					6V	12V	15V	24V	30V
Typical values ¹	☀				13,0	22,3	25,4	36,2	28,8
	☀	☀			26,8	35,8	39,6	52,8	63,9
	☀		☀		-	-	39,6	52,8	63,9
	☀			☀	-	-	249,0	319,2	291,0
Max values ²	☀				40,0	62,0	78,0	78,0	97,0
	☀	☀			78,0	102,0	108,0	126,0	139,0
	☀		☀		-	-	117,0	156,0	156,0
	☀			☀	-	-	1017,0	1086,0	1105,0

1) Average

2) short-term max values during operation

13 Dimensional Drawing Cable Version



Shown with accessory
510314 sintered filter cap.

14 Dimensional Drawing Plug Version



Shown with accessory
510314 sintered filter cap.

15 Accessories (optional)

Calibration hose connection adapter	510025	for Hygro-Thermo-Baro Transmitter
Replacement hygro-thermo measuring element	510487	Calibrated replacement measuring element for exchange
Sinter-filter-Cap The filter serves for protecting the sensor elements of the Hygro-thermo transmitter against dust in case of field application	510314	Material: Stainless steel Dimensions: Ø 20 x 25mm.
Protective cap The protective cap is used to protect the measuring elements of the Hygro-Thermo-BaroSensor from damage.	510488	Material: Plastic - POM
Connection cable compl.	510607	1 m - M12 – 8 pol. on M16 – 5 pol.
Adapter Y-Splitter	214648	Y-Splitter M12; 8 PIN; male on two female. With this adapter, the cable from a sensor can be joined with the cable from a weather & radiation protection ventilated to have only one connection cable.
Wall bracket ZA50	1.1005.54.903	for Hygro-Thermo-Baro Transmitter
Weather and radiation protection without fan Für Mastrohr Montage Ø 35 ... 50mm.	1.1025.55.000	By using the weather and radiation protection in combination with suitable temperature and humidity sensors, the possibility of errors being influenced by radiation, precipitation or damage is minimized.
Weather and radiation protection with fan 12 ... 30V DC / 2W, with 5m cable. For mast tube assembly Ø 35 ... 50mm.	1.1025.80.101	By using the weather and radiation protection in combination with suitable temperature and humidity sensors, the possibility of errors being influenced by radiation, precipitation or damage is minimized. Even more precise measurement results can be achieved by using this ventilated weather and radiation protection. The ventilation reduces errors that occur when measuring in a weather and radiation protection through the creation of the so-called "own climate".

Please contact us for other accessories such as cables, power supply units, masts, as well as for additional mast- or system-constructions.

16 Appendix

16.1 Calibration of the Sensor

It is possible to calibrate the sensor for the measured values Temperature, Rel. humidity and Air pressure. The individual steps for calibration are described below in the following points. Telegram 6 should be used to calibrate the sensor. The calibration result is not saved on the sensor. Any adjustment does not form part of the calibration process.

16.2 Calibration of Temperature / Humidity

The calibration of humidity and air temperature corresponds to the calibration of conventional sensors.

We recommend the following procedure for humidity calibration:

1. Storage of the device for several hours at rather low humidity levels
2. Carrying out the calibration in accordance with DKD guideline 5-8 "Calibration of hygrometers for direct measurement of relative humidity"; Procedure A1, A2, B1 or B2
3. Consideration of the adjustment time also according to the DKD guideline 5-8 "Calibration of hygrometers for the direct recording of the relative humidity"

To prevent confusion, the hygro-thermo measuring element must be set parameter CF 1 after calibrating. This ensures that on exchange of the hygro-thermo sensor element the air temperature / humidity is no longer output.

16.3 Calibration of Air Pressure

To calibrate the internal air pressure sensor, it is necessary to operate the sensor "open" so as to ensure pressure equalisation between the housing interior and the outside air is as fast as possible.

To avoid this shortcoming, it is recommended removing the hygro-thermo sensor element on pressure calibration. The air pressure of the sensor is equalized via the cable. This must be taken into account when calibrating.

In practice the installed pressure equalisation with the cable is sufficiently fast with fluctuations in barometric air pressure. For calibration such equalisation may be too slow.

Two options for air pressure calibration are described in individual steps below. Calibration of the air pressure in the pressure chamber and calibration of the air pressure via hose connections.

16.3.1 Calibration of the air pressure in the pressure chamber

To calibrate air pressure, the following steps are necessary:

1. Switch off supply voltage

Attention:

Before and when replacing the hygro-thermo measuring element, the person which performing the work must have potential equalization. Electrostatic discharges via the hygro-thermo measuring element can cause damage.

2. Operation with filter cap: Remove filter cap upwards.

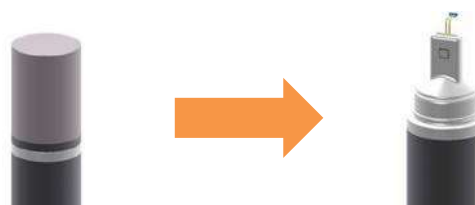

3. Operation without filter cap: Pull off Protective cap upwards.

Attention:

Do not bend the PT-1000 sensor when removing and reassembling. The PT 1000 must be angled at 90°.



When re-assembling, clip protective cap-back on so there is no longer a gap. The PT-1000 sensor must not sit behind a arm.

4. Pull off sensor element upwards.

Note:

Do not touch the highly sensitive hygro-thermo sensor element on the **sensor surface**.

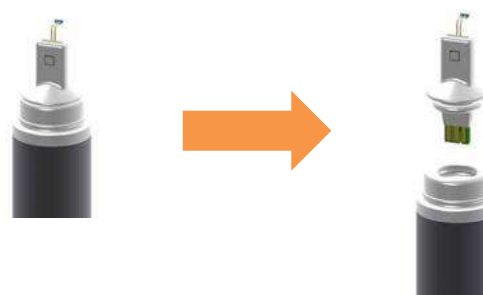

- 5 Apply voltage and reference pressure to sensor and calibrate.

6. To return to initial state, perform steps 4, 3, 2, 1.

Note:

There should be no gaps between the individual components after disassembly and re-mounting of the sensor element.

16.3.2 Calibration of the air pressure via hose connections

To calibrate air pressure, the following steps are necessary:

1. Switch off supply voltage

Attention:

Before and when replacing the hygro-thermo measuring element, the person which performing the work must have potential equalization. Electrostatic discharges via the hygro-thermo measuring element can cause damage.

2. Operation with filter cap: Remove filter cap upwards.

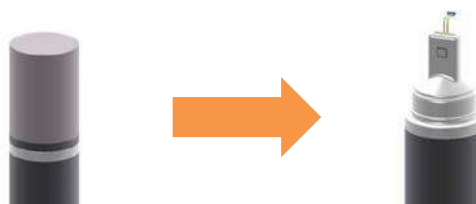

3. Operation without filter cap: Pull off protective cap upwards, unclip.

Attention:

Do not bend the PT-1000 sensor when removing and reassembling. The PT 1000 must be angled at 90°.

When re-assembling, clip protective cap back on so there is no longer a gap. The PT-1000 sensor must not sit behind a arm.



4. Pull off sensor element upwards.

Note:

Do not touch the highly sensitive hygro-thermo sensor element on the **sensor surface**.

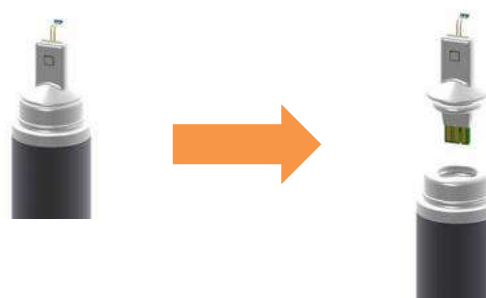

5. Plug on the Calibration hose connection adapter 510025

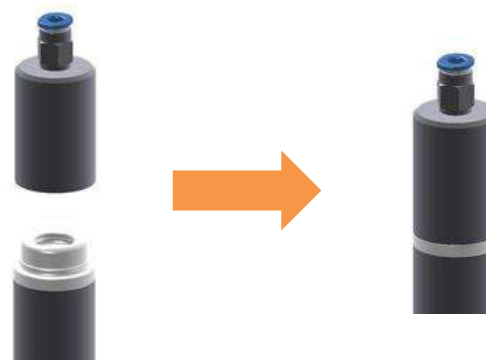

- Supply sensor via junction box.

Note:

The junction box is available upon request for calibration labs.

- Connect junction box to reference pressure.

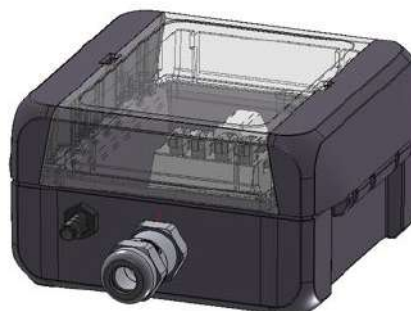

- Supply the sensor with reference pressure via the hose connection adapter and voltage via the junction box. Then perform calibration.
- To return to initial state, perform steps 8 ... 1.

Note:

There should be no gaps between the individual components after disassembly and re-mounting of the sensor element.

16.4 Calculation of Air Pressure

The air pressure is output in hPa and indicates the air pressure at the measuring site. This air pressure value is also known as QFE. With indication of the station height the sensor can calculate the reduced air pressure referred to sea level. This value is also known as QFF. If the sensor is located above sea level, the reduced air pressure at sea level is always higher than the measured air pressure.

The reduced air pressure (QFF) is the air pressure which is used as a reference value for example by official bodies such as the meteorological services.

When calculating, the height difference between the measuring height and the mounting height of the sensor should be taken into account. The air pressure of the sensor is compensated via the cable. The air pressure is measured at the height of the sensor (see sketch for measuring height). Pressure fluctuations, e.g. closing a door in an airtight room, are largely dampened by the time constant of over 8s.

Measuring height
Hygro-Thermo-Baro
/ 1.1006.54.7xx

(Cable end) Hygro-
Thermo-Baro /
1.1006.54.xxx



Figure 3: Example Pressure Equalization

16.5 Exchange of Hygro-Thermo Sensor Element

The sensor is designed so that the hygro-thermo sensor element can be exchanged.

To exchange the hygro-thermo sensor element, parameter CF must thus be set to 0 or the air temperature / humidity will no longer be output.

To avoid accidentally confusing the hygro-thermo sensor element with the present sensors, the parameter CF must be set to 1 after calibration. This ensures that only calibrated sensors are used.

The following steps are necessary to exchange the hygro-thermo sensor element:

1. Switch off supply voltage

Attention:

Before and when replacing the hygro-thermo measuring element, the person which performing the work must have potential equalization. Electrostatic discharges via the hygro-thermo measuring element can cause damage.

2. When operating with filter cap: Remove filter cap



3. Pull off mounting ring upwards, unclip.

Attention:

Do not bend the PT-1000 sensor when removing and reassembling. The PT 1000 must be angled at 90°.

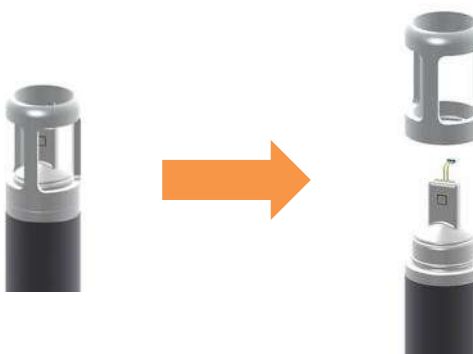

4. Pull off sensor element upwards.

Note:

Do not touch the highly sensitive hygro-thermo sensor element on the **sensor surface**.

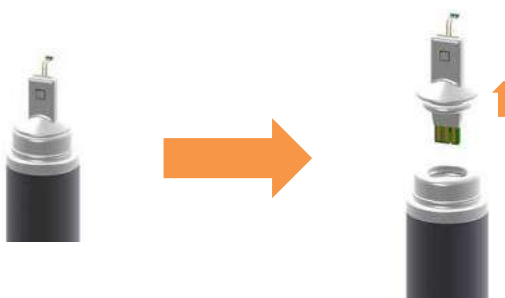

5. Insert the new sensor element from above.

Note:

Do not touch the highly sensitive hygro-thermo sensor element on the **sensor surface**.

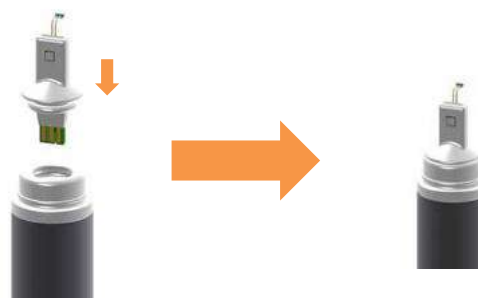

The sensor element is protected against polarity reversal and will only fit into the recess one way.

6. Insert the measuring element until it protrudes out 15mm.

7. Fit the mounting ring on top and clip on so there is no longer a gap. The PT-1000 sensor must not sit behind a arm.

Attention:

Do not bend the PT-1000 sensor when removing and reassembling. The PT 1000 must be angled at 90°.

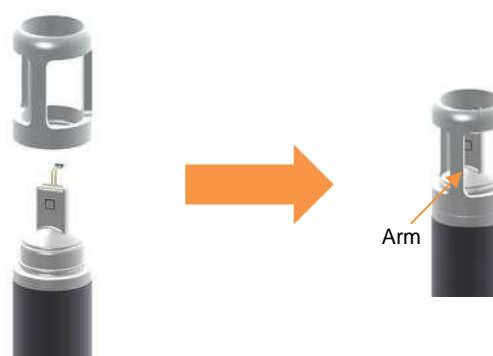

8. When operating with filter cap: Fit filter cap back on.



Note:

There should be no gaps between the individual components after exchanging the sensor element.

9. Apply voltage to sensor.

All adjustment parameters for the hygro-thermo sensor element are stored on the sensor element. The sensor is fully functional after exchange.

16.6 Table and Figures Overview

Table overview:

Table 1: Cable assignment of the sensor 1.1006.54.x8x	10
Table 2: Cable assignment of the sensor 1.1006.54.1xx	10
Table 3: Plug assignment of the sensor 1.1006.54.78x	10
Table 4: Plug assignment of the sensor 1.1006.54.74x, 1.1006.54.76x	11
Table 5: Conversion analog outputs	15
Table 6: Status Word.....	19
Table 7: List of commands	20
Table 8: MODBUS Frame	38
Table 9: MODBUS Exceptions	38
Table 10: MODBUS Input Register.....	39
Table 12: Measured value Telegram 1	41
Table 13: Measured Value-Telegram 2	42
Table 14: Measured value-Telegram 3	43
Table 15: Measured Value-Telegram 4	44
Table 16: Measured Value-Telegram 6	45
Table 17: Measured Value-Telegram 7	46

Figures overview:

Figure 1: Example Pressure Equalization.....	7
Figure 2: Hygro-thermo Measuring Element.....	13
Figure 3: Example Pressure Equalization.....	55

17 EC-Declaration of Conformity

Manufacturer: Adolf Thies GmbH & Co. KG
 Hauptstraße 76
 37083 Göttingen, Germany
<http://www.thiesclima.com>

Product: Hygro-Thermo-Baro Transmitter

Doc. Nr. 2014-44929_CE

Article Overview:

1.1006.54.080 1.1006.54.081 1.1006.54.087 1.1006.54.141 1.1006.54.160 1.1006.54.161 1.1006.54.741 1.1006.54.760 1.1006.54.761 1.1006.54.780
 1.1006.54.781

The indicated products correspond to the essential requirement of the following European Directives and Regulations:

2014/30/EU	26.02.2014	DIRECTIVE 2014/30/EU OF THE EUROPEAN PARLIAMENT AND OF THE COUNCIL of 26 February 2014 on the harmonisation of the laws of the Member States relating to electromagnetic compatibility.
2014/35/EU	26.02.2014	DIRECTIVE 2014/35/EU OF THE EUROPEAN PARLIAMENT AND OF THE COUNCIL of 26 February 2014 on the harmonisation of the laws of the Member States relating to the making available on the market of electrical equipment designed for use within certain voltage limits.
2017/2102/EU	15.11.2017	DIRECTIVE (EU) 2017/2102 of the European Parliament and of the Council of November 15, 2017 amending Directive 2011/65 / EU on the restriction of the use of certain hazardous substances in electrical and electronic equipment.
2012/19/EU	13.08.2012	DIRECTIVE 2012/19/EU OF THE EUROPEAN PARLIAMENT AND OF THE COUNCIL of 4 July 2012 on waste electrical and electronic equipment (WEEE).

The indicated products comply with the regulations of the directives. This is proved by the compliance with the following standards:

DIN EN 55016-2-1	2019-11	Specification for radio disturbance and immunity measuring apparatus and methods - Part 2-1: Methods of measurement of disturbances and immunity - Conducted disturbance measurements (CISPR 16-2-1:2014 + A1:2017); German version EN 55016-2-1:2014 + A1:2017
DIN EN IEC 61000-4-3	2021-11	Electromagnetic compatibility (EMC) - Part 4-3: Test and measurement procedures - Testing of immunity to high-frequency electromagnetic fields
DIN EN 61000-4-4	2013-04	Electromagnetic compatibility (EMC) - Part 4-4: Test and measurement methods - Testing of immunity to fast transient electrical disturbances / burst
DIN EN 61000-4-5	2019-03	Electromagnetic compatibility (EMC) - Part 4-5: Test and measurement procedures - Testing of immunity to surge voltages
DIN EN 61000-4-6	2014-08	Electromagnetic compatibility (EMC) - Part 4-6: Test and measurement methods - Immunity to conducted disturbances, induced by high-frequency fields
DIN EN IEC 61000-6-2	2019-11	Electromagnetic compatibility Immunity for industrial environment
DIN EN 61000-6-3:2007 + A1:2011	2011-09	Electromagnetic compatibility (EMC). Generic standards. Emission standard for residential, commercial and light-industrial environments
DIN EN 61010-1	2020-03	Safety requirements for electrical equipment for measurement, control, and laboratory use. General requirements
DIN EN 61326-1	2013-07	Electrical equipment for measurement, control and laboratory use. EMC requirements. General requirements
DIN EN IEC 62368-1	2016-04	Audio/video, information and communication technology equipment - Part 1: Safety requirements (IEC 62368-1:2014)
DIN EN IEC 63000	2019-05	Technical documentation for the assessment of electrical and electronic products with respect to the restriction of hazardous substances.

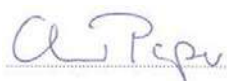

General Manager - Dr. Christoph Peper



Development Manager - ppa. Jörg Peterreit

This declaration certifies the compliance with the mentioned directives, however does not include any warranty of characteristics.
 Please pay attention to the security advises of the provided instructions for use.

18 UK-CA-Declaration of Conformity

Manufacturer: Adolf Thies GmbH & Co. KG
 Hauptstraße 76
 37083 Göttingen, Germany
<http://www.thiesclima.com>

Product: Hygro-Thermo-Baro Transmitter

Doc. Nr. 2014-44929_CA

Article Overview:

1.1006.54.080 1.1006.54.081 1.1006.54.087 1.1006.54.141 1.1006.54.160 1.1006.54.161 1.1006.54.741 1.1006.54.760 1.1006.54.761 1.1006.54.780
 1.1006.54.781

The indicated products correspond to the essential requirement of the following Directives and Regulations:

1091	08.12.2016	The Electromagnetic Compatibility Regulations 2016
1101	08.12.2016	The Electrical Equipment (Safety) Regulations 2016
RoHS Regulations 2012	01.01.2021	The Restriction of the Use of Certain Hazardous Substances in Electrical and Electronic Equipment Regulations 2012
3113	01.01.2021	Regulations: waste electrical and electronic equipment (WEEE)

The indicated products comply with the regulations of the directives. This is proved by the compliance with the following standards:

BS EN 55016-2-1+A1:2014-07-31	31.07.2014	Specification for radio disturbance and immunity measuring apparatus and methods. Methods of measurement of disturbances and immunity. Conducted disturbance measurements
BS EN IEC 61000-4-3	04.11.2020	Electromagnetic compatibility (EMC). Testing and measurement techniques. Radiated, radio-frequency, electromagnetic field immunity test
BS EN 61000-4-4	30.11.2012	Electromagnetic compatibility (EMC). Testing and measurement techniques. Electrical fast transient/burst immunity test
BS EN 61000-4-5+A1	30.09.2014	Electromagnetic compatibility (EMC). Testing and measurement techniques. Surge immunity test
BS EN 61000-4-6	28.02.2014	Electromagnetic compatibility (EMC). Testing and measurement techniques. Immunity to conducted disturbances, induced by radio-frequency fields
BS EN IEC 61000-6-2	25.02.2019	Electromagnetic compatibility (EMC). Generic standards. Immunity standard for industrial environments
BS EN IEC 61000-6-3	30.03.2021	Electromagnetic compatibility (EMC). Generic standards. Emission standard for equipment in residential environments
BS EN 61010-1+A1	31.03.2017	Safety requirements for electrical equipment for measurement, control, and laboratory use. General requirements
BS EN IEC 61326-1	07.06.2021	Electrical equipment for measurement, control and laboratory use. EMC requirements. General requirements
BS EN IEC 62368-1	2016-04	Audio/video, information and communication technology equipment. Safety requirements
BS EN IEC 63000	10.12.2018	Technical documentation for the assessment of electrical and electronic products with respect to the restriction of hazardous substances

This declaration of conformity is issued under the sole responsibility of the manufacturer.

Legally binding signature:



General Manager - Dr. Christoph Peper

Legally binding signature:



Development Manager - ppa. Jörg Peterit

This declaration certifies the compliance with the mentioned directives, however does not include any warranty of characteristics.

Please pay attention to the security advises of the provided instructions for use.

19 More Information / Documents as download

Further information can be found in the short instructions for use. These document and also the instruction for use are available for download under the following links.

Short instruction for use

https://www.thiesclima.com/db/dnl/1.1006.54.xxx_Hygro_Thermo_Baro_Compact_FirstSteps_eng.pdf

Instruction for use

https://www.thiesclima.com/db/dnl/1.1006.54.xxx_Hygro_Thermo_Baro_Compact_eng.pdf

**Please contact us for your system requirements.
We advise you gladly.**

ADOLF THIES GMBH & CO. KG

Meteorology and environmental metrology
Hauptstraße 76 · 37083 Göttingen · Germany
Phone +49 551 79001-0 · Fax +49 551 79001-65
info@thiesclima.com

www.thiesclima.com

